

# Niobrara MM16 Cable

The Niobrara MM16 Cable is an RS-232 serial data cable intended to be used to connect a Caterpillar® Customer Communication Module to a Niobrara QUCM. One end of the cable is fitted with an RJ45 plug for connection to a serial port of the QUCM; the other end terminates in a female DB25 connector for connection to the serial port of the CCM.

## Configuration

The pinout for the MM16 is as follows:

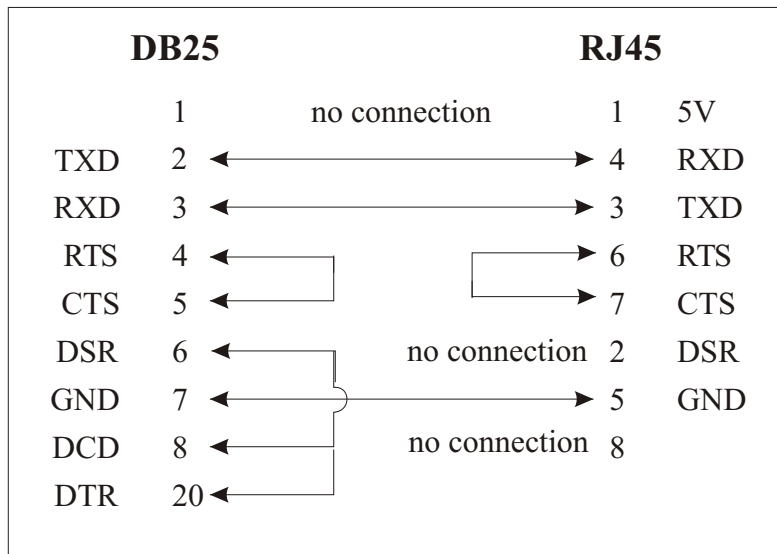

## Installation:

Connect the RJ45 end of the MM16 cable to a serial port of the QUCM set for RS-232. Connect the 25-pin DB25 end of the adapter to the serial port of the CCM. The CCM must be configured for direct connection and not modem connection.