

# Niobrara Research & Development Corporation

P.O. Box 3418; Joplin, MO 64803  
Telephone: (417) 624-8918 Facsimile: (417) 624-8920 www.niobrara.com

## MSTD-206 Momentum® Serial Tophat

Effective: 05 December,

2007

### Introduction

The Momentum® Serial Tophat (MST) provides a serial communications adapter for Modicon Momentum I/O bases. The MSTD-206 allows a KYZ output to be easily added to an existing Modbus network with other Modbus network devices, using the Modicon Momentum 170 ADI 340 00 base.

The MSTD-206 communicates Modbus RTU protocol at 9600 baud with 8 data bits and even or no parity.

The MSTD-206 is powered by the Momentum base. LED indicators show the state of POWER(A), Serial TX(T) and RX(R). The green A LED should be on if the MSTD-206 is properly powered by the base. The A light will flash slowly if the unit is set to slave address 0. The yellow T light is on while the MSTD-206 is transmitting data while the R light indicates data arriving at the MSTD-206.

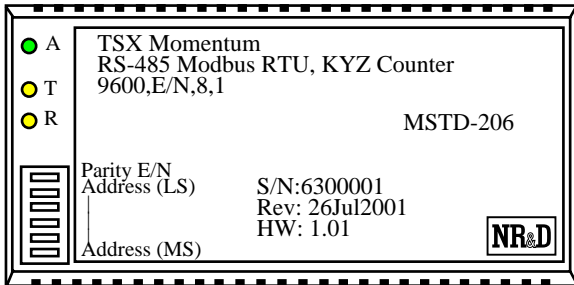

Figure 1 MSTD-206 Layout

### MSTD-206 Configuration

The MSTD-206 is configured through a 6 position DIP switch on its front. Switches 1, 2, 3, 4, and 5 control Slave Address while switch 6 sets the parity. Refer to any other MST Instruction manual for further information on setting the DIP switches.

**NOTE:** The MSTD-206 only reads the DIP switches on power-up. Power must be cycled after changing the Parity or Slave Address.

1 = ON (up), 0 = OFF (down)

**NOTE:** Power must be cycled after changing the Parity or Slave Address for the change to take effect.

### Network Connection

The MSTD-206 has a 5 position screw terminal 4-wire, connection. The pinout is shown in Figure 2.

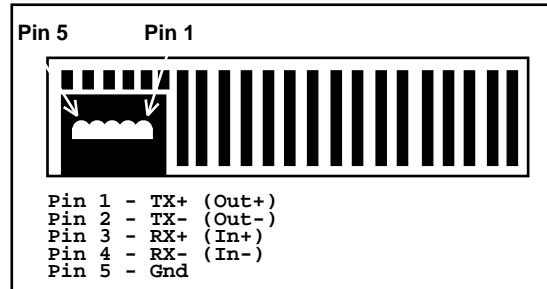

Figure 2 5 pin RS-485 Port

### KYZ Connections

The MSTD-206 MUST be installed on the 170 ADI 340 00 base for proper functioning. This base is a 16 input 24 VDC base. For each KYZ device (up to eight), the K terminal may be connected to the base's power supply. The Y terminal should be connected to the odd number inputs of the base, and the Z terminal should be connected to the even number inputs. For two-wire operation, the same connections apply, but omit the even numbered inputs. An example of this connection is shown below.

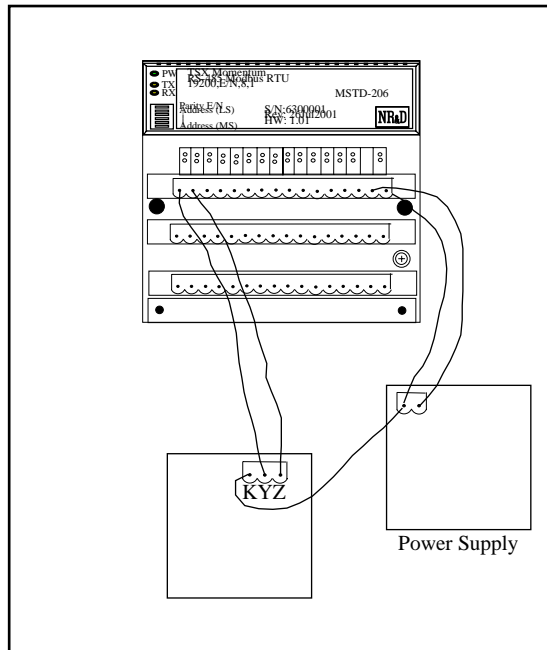

Figure 3 KYZ Wiring Example



## Register List

The MSTD-206 mimics the standard Modicon Ethernet Communication Adapter with some additional register support. The Output registers are zeroed on power-up and when the watchdog expires between write messages. The Watchdog register value is written to EEPROM for permanent setting. Setting the slave address to 0 returns the watchdog to factory default.

**Table 1 MSTD-206 Register List**

Register	Description
4x00001	Read - Status of all Base Inputs
4x00002	Read/Write - KYZ Counter 1
4x00003	Read/Write - KYZ Counter 2
4x00004	Read/Write - KYZ Counter 3
4x00005	Read/Write - KYZ Counter 4
4x00006	Read/Write - KYZ Counter 5
4x00007	Read/Write - KYZ Counter 6
4x00008	Read/Write - KYZ Counter 7
4x00009	Read/Write - KYZ Counter 8
4x000010	Read - Lower Byte = Overflow Flag Bits for each counter. Upper Byte, bit 8 = Powerup bit. Register will return to zero after being read.
4x00200 and 4x61441	Base Output Watchdog (0.01 second) Default = 3000 (30 seconds) The MSTD-206 must receive a write within the timeout or the outputs will zero.
4x00201 and 4x63489	Size of Status Block (const = 12)
4x00202 and 4x63490	Number of Input Words
4x00203 and 4x63491	Number of Output Words
4x00204 and 4x63492	Module Base ID code
4x00205 and 4x63493	Module Revision Number
4x00206 - 4x00209 and 4x63494 - 4x63497	N/A
4x00210 and 4x63498	Module Health (8000 is good Health)
4x00211 and 4x63499	Last I/O module error #
4x00212 and 4x63500	Count of I/O module errors

P